



eFOLDi

# Flight Safety Certificate

**eFOLDi mobility scooter**



**Model: Explorer (MK1.5)**

SUNTECH UK LTD (Trading as eFOLDi)  
[www.efoldi.com](http://www.efoldi.com)



eFOLDi



**This battery conforms to the IATA (International Air Transport Association) requirements and specifications for transport by mobility impaired passengers on Passenger Aircraft as set out in Section 2.3.2.4. of the IATA Dangerous Goods Regulations (edition 63).**

***NB: Individual Airlines/Operators and/or Nations may impose more rigorous restrictions than those outlined under the international minimums referred to above.***

**Battery information:**

**eFOLDi FarReach, Lithium-Ion, Dry, Non spillable, 24VDC, 12ah, 288Wh**

**Dimensions: 19.5x8.5x11cm**

**Weight:1.8kg/each**

**Key lock: Yes**

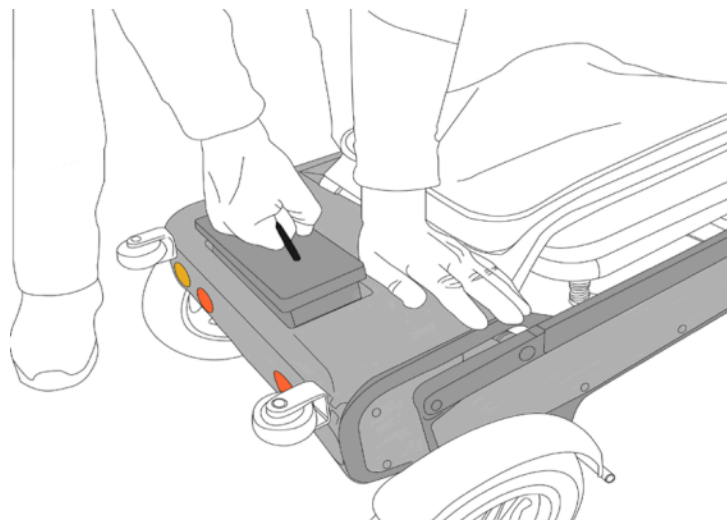

**Lift the battery from scooter after unlocking it using the key**



eFOLDi

**Scooter weight: 17kg without battery/19kg with battery**

**Scooter fully folded size: 66x56x40cm (26x22x15.6inch)**

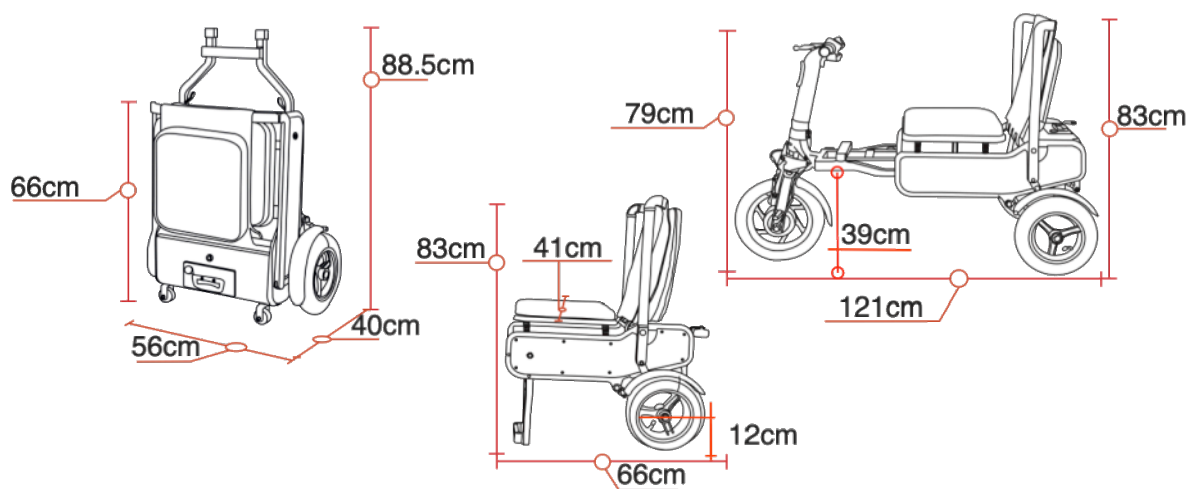

Dimensions

# 材料安全数据表

## Material Safety Data Sheet

本报告本年度有效  
有效期至 2024 年 12 月 31 日

样品名称: 可充电锂离子电池

Sample name: Rechargeable Lithium-ion Battery

样品型号: eFOLDi FarReach Battery

Sample model:

委托单位: SunTech UK Ltd

Applicant:

签发时间 Date of issue: 2023.12.13

Written by

陈杰刚

Approved by

段江涛

深圳天湖计量检测股份有限公司

Shenzhen Tiansu Calibration and Testing Co., Ltd.



\* The MSDS is prepared based on the information provided by client. The contents and formats of this MSDS are revised as per client's request. 这份材料安全数据表是根据客户提供的信息编辑，其内容和格式按客户要求来修订。

## 第一部分-化学品及企业标识

**Section 1-Chemical Product and Company Identification**

产品名称 <b>Product Name</b>	可充电锂离子电池 Rechargeable Lithium-ion Battery
型号 <b>Model</b>	eFOLDi FarReach Battery
商标 <b>Trade Mark</b>	-
额定参数 <b>Ratings</b>	24V/12Ah/288Wh
重量 <b>Weight</b>	1.879kg
生产单位 <b>Manufacturer</b>	东莞一展电子科技有限公司 Dongguan Yizhan Electronic Technology Co., Ltd
生产单位地址 <b>Manufacturer Address</b>	广东省东莞市常平镇土塘村天桥西路2号龙之祥长盛科技园2号厂房 No. 2, LongZhiXiang ChangSheng Science and Technology Park, No. 2, West TianQiao Road, TuTang Village, ChangPing Town, DongGuan City, GuangDong Province
应急电话 <b>Emergency Telephone</b>	13510702894
传真 <b>Fax</b>	-

## 第二部分-成分信息

**Section 2- Composition Information**

化学成分 <b>Chemical Composition</b>	化学式 <b>Chemical Formula</b>	CAS号 <b>CAS No.</b>	重量含量 (%) <b>Weight (%)</b>
钴酸锂 Lithium cobaltate	LiCoO <sub>2</sub>	12190-79-3	15 - 40
石墨 Graphite	C	7782-42-5	10 - 30
六氟磷酸锂 Lithium hexafluorophosphate	LiPF <sub>6</sub>	21324-40-3	10 - 30
铜箔 Copper	Cu	7440-50-8	7-13



铝箔 Aluminium	Al	7429-90-5	5-10
镍 Nickel	Ni	7440-02-0	1-5

## 第三部分-危险性概述

**Section 3- Hazards Identification**

紧急情况概述 <b>Emergency overview</b>	不适用 N/A
标签元素 <b>Label elements:</b>	
危险标签图 <b>Hazard pictogram(s)</b>	不适用 Not Applicable
提示语 <b>Signal word</b>	不适用 Not Applicable
危险声明 <b>Hazard statement(s)</b>	不适用 Not Applicable
预防声明 <b>Precautionary statement(s):</b>	
预防 <b>Prevention</b>	不适用 Not Applicable
反应 <b>Response</b>	不适用 Not Applicable
废弃处理 <b>Disposal</b>	不适用 Not Applicable
环境危害 <b>Environmental hazards:</b>	无相关信息 No relevant information
重要症状 <b>Important symptoms:</b>	见第11部分更多信息 See section 11 for more information

## 第四部分-急救措施

**Section 4- First Aid Measures**

眼睛接触 <b>Eye contact</b>	万一接触，立即用大量的清水冲洗至少15分钟，翻起上下眼睑，直到化学的残留物消失为止，迅速就医。 Flush eyes with plenty of water for least 15 minutes, occasionally lifting the upper and lower eyelids. Get medical aid.
皮肤接触 <b>Skin contact</b>	万一接触，用大量的水冲洗至少15分钟，同时除去污染的衣物和鞋子，迅速就医。 Remove contaminated clothes and rinse skin with plenty of water or shower for 15 minutes. Get medical aid.
吸入 <b>Inhalation</b>	立即从暴露处移至空气清新处，如果呼吸困难给予输氧，立即就医。 Remove from exposure and move to fresh air immediately. Use oxygen if available.
摄入 <b>Ingestion</b>	饮用两杯牛奶或水，如果当事人仍然清醒可以采取催吐的方法，并且立即就医。 Give at least 2 glasses of milk or water. Induce vomiting unless patient is unconscious. Call a physician.



第五部分-消防措施

**Section 5- Fire Fighting Measures**

燃点 <b>Flash Point</b>	不适用 N/A
自燃温度 <b>Auto-Ignition Temperature</b>	不适用 N/A
灭火介质 <b>Extinguishing Media</b>	碳氢表面活性剂, 二氧化碳 Hydrocarbon surfactant, CO <sub>2</sub>
特殊灭火程序 <b>Special Fire-Fighting Procedures</b>	自给式呼吸器 Self-contained breathing apparatus
异常火灾或爆炸 <b>Unusual Fire and Explosion Hazards</b>	当电芯暴露于过热的环境中时, 安全阀可能会打开 Cell may vent when subjected to excessive heat-exposing battery contents
燃烧产生的危险物品 <b>Hazardous Combustion Products</b>	一氧化碳, 二氧化碳, 锂氧化物烟气 Carbon monoxide, carbon dioxide, lithium oxide fumes.

第六部分-泄露应急处理

**Section 6- Accidental Release Measures**

**个人预防措施、保护设备和应急程序:**

如果电池被泄露, 让人员离开该区域直到烟雾消散。提供最大限度的通风, 清除有害气体。首选的反应就是离开这个地区并消散气体, 避免皮肤和眼睛接触或吸入气体。用吸收剂清除溢出的液体然后焚烧。如果电池泄漏发生时, 液体可以用砂、泥土或其他惰性物质来吸收, 污染区域应该保持通风。

**Personal precautions, protective equipment and emergency procedures:**

If the battery is released, remove personnel from area until fumes dissipate. Provide maximum ventilation to clear out hazardous gases. The preferred response is to leave the area and allow the vapors to dissipate, Avoid skin and eyes contact or inhalation of vapors. Remove spilled liquid with absorbent and incinerated. If leakage of the battery happens, liquid could be absorbed by using sand, earth or other inert substance and contaminated area should be ventilated meantime.

**环境预防措施:**

不允许产品到达排水系统或任何水源。  
如果渗透进排水系统或任何水源, 通知相应的部门。  
不允许进入下水道/表面或地下水。

**Environment precautions:**

Do not allow product to reach sewage system or any water source.  
Inform respective authorities in case of seepage into water course or sewage system.  
Do not allow to enter sewers/ surface or ground water.

**抑制和清理材料的方法:**

如果电池外壳被拆除, 少量电解液可能会泄漏。收集所有材料放进一个塑料容器。根据当地的法律法规来处置, 避免可溶物质进入大地、下水道或水源。

**Methods and material for containment and cleaning up:**

If battery casing is dismantled, small amounts of electrolyte may leak. Collect all released material in a plastic



lined container. Dispose off according to the local law and rules, Avoid leached substances to get into the earth, canalization or waters.

第七部分-操作处置和储存

**Section 7- Handling and Storage**

<p>操作处置 <b>Handling</b></p>	<p>禁止打开、毁坏或焚烧电池，因为电池有可能在这些处理过程中发生爆炸、破裂或泄露等事故。 禁止将电池短路、过充、强制放电或扔入火中。 禁止挤压或刺穿电池，或将电池浸入溶液中。 The battery should not be opened, destroyed or incinerate, since they may leak or rupture and release to the environment the ingredients that they contain in the hermetically sealed container. Do not short circuit terminals, or over charge the battery, forced over-discharge, throw to fire. Do not crush or puncture the battery, or immerse in liquids.</p>
<p>储存 <b>Storage</b></p>	<p>禁止物理或电滥用，禁止高温储存，最好将电池储存在阴凉、干燥、通风及温度变化较小的环境中。 禁止将电池接触加热设备，或将电池长时间直接暴露在阳光中。 Avoid mechanical or electrical abuse. Storage preferably in cool, dry and ventilated area, which is subject to little temperature change. Storage at high temperatures should be avoided. Do not place the battery near heating equipment, nor expose to direct sunlight for long periods.</p>
<p>其他要注意的防范措施 <b>Other Precautions</b></p>	<p>拆解、挤压、直接放入火中或高温条件下，电池可能发生爆炸和燃烧。 禁止短接或将电池正负极错误的安装在设备中。 The battery may explode or cause burns, if disassembled, crushed or exposed to fire or high temperatures. Do not short or install with incorrect polarity.</p>

第八部分-接触控制和个体防护

**Section 8- Exposure Controls/Personal Protection**

<p>设计控制 <b>Engineering Controls</b></p>	<p>设计局部排气通风或其它设计来控制粉尘、雾、烟雾和气体。 Use local exhaust ventilation or other engineering controls to control sources of dust, mist, fumes and vapor. Keep away from heat and open flame. Store in a cool, dry place.</p>
---	---





个人防护装备 <b>Personal Protective Equipment</b>	呼吸防护: 在正常情况下不需要。 皮肤和身体防护: 在正常情况下不需要, 如果处理一个裂开的或泄漏的电池需要穿戴适当的防护服和手套。 手保护: 如果处理一个裂开的或泄漏的电池需要戴适当手套。 眼睛保护: 在正常情况下不需要, 如果处理一个裂开的或泄漏的电池需要戴上安全眼镜。 Respiratory Protection: Not necessary under normal conditions. Skin and body Protection: Not necessary under normal conditions, Wear suitable protective clothing and gloves if handling an open or leaking battery. Hand protection: Wear suitable gloves if handling an open or leaking battery. Eye Protection: Not necessary under normal conditions, Wear safety glasses if handling an open or leaking battery.
其它防护装备 <b>Other Protective Equipment</b>	在工作区域应该有一个立即可以使用的安全淋浴和喷水洗眼器。 Have a safety shower and eye wash fountain readily available in the immediate work area.
卫生措施 <b>Hygiene Measures</b>	在工作区域不得进食, 饮水或吸烟。 Do not eat, drink, or smoke in work area. Maintain good housekeeping.
第九部分-物理和化学特性 <b>Section 9- Physical and Chemical Properties</b>	
颜色 <b>Color</b>	黑色 Black
气味 <b>Odour</b>	不适用 Not Applicable
酸碱度 <b>pH</b>	不适用 Not Applicable
熔点/凝固点 <b>Melting point/freezing point</b>	不适用 Not Applicable
沸点、沸点范围: <b>Boiling Point and Boiling range</b>	不适用 Not Applicable
易燃度 <b>Flash Point</b>	不适用 Not Applicable
自燃或爆炸的上、下极限 <b>Upper/lower flammability or explosive limits</b>	不适用 Not Applicable
蒸汽压 <b>Vapor Pressure</b>	不适用 Not Applicable



蒸汽密度 <b>Vapor Density</b>	不适用 Not Applicable
相对密度 <b>Relative density</b>	不适用 Not Applicable
水溶性 <b>Solubility in Water</b>	不适用 Not Applicable
自燃温度 <b>Auto-ignition temperature</b>	不适用 Not Applicable
分解温度 <b>Decomposition temperature</b>	不适用 Not Applicable
蒸发速率 <b>Evaporation rate</b>	不适用 Not Applicable
易燃性(土壤、天然气) <b>Flammability (soil, gas)</b>	不适用 Not Applicable
粘性 <b>Viscosity</b>	不适用 Not Applicable
第十部分 稳定性和反应活性 <b>Section 10- Stability and reactivity</b>	
稳定性 <b>Stability</b>	产品在第七部分所述的条件下稳定 The product is stable under conditions described Section 7
应避免的条件 <b>Conditions to Avoid</b>	加热 70°C 以上或焚烧、变形、毁坏、粉碎、拆卸、过充电、短路，长时间暴露在潮湿的条件下。 Heat above 70°C or incinerate. Deform, Mutilate, Crush, Disassemble, Overcharge, Short circuit, Expose over a long period to humid conditions.
不兼容的材料 <b>Incompatible Materials</b>	氧化剂，酸，碱。 Oxidizing agents, acid, base.
危险分解物 <b>Hazardous Decomposition Products</b>	一氧化碳、二氧化碳、氧化锂烟雾。 Carbon monoxide, carbon dioxide, lithium oxide fumes.
危险反应的可能性 <b>Possibility of Hazardous Reaction</b>	不适用 Not Applicable
第十一部分-毒理学资料 <b>Section 11 - Toxicological Information</b>	
刺激	如果电芯的外壳受到机械、热或电的滥用到达一定程度，会发生刺激的风险。



<b>Irritation</b>	如果发生这种情况，可能会刺激皮肤、眼睛和呼吸道。 Risk of irritation occurs only if the cell is mechanically, thermally or electrically abused to the point of compromising the enclosure. If this occurs, irritation to the skin, eyes and respiratory tract may occur.
致过敏 <b>Sensitization</b>	不适用 Not Applicable
影响神经系统 <b>Neurological Effects</b>	不适用 Not Applicable
致畸 <b>Teratogenicity</b>	不适用 Not Applicable
再生毒性 <b>Reproductive Toxicity</b>	不适用 Not Applicable
诱变(遗传效应) <b>Mutagenicity (Genetic Effects)</b>	不适用 Not Applicable
附带材料毒理性 <b>Toxicologically Synergistic Materials</b>	不适用 Not Applicable

第十二部分-生态学资料

**Section 12- Ecological Information**

生态毒性 <b>Ecological Toxicity</b>	不适用 Not Applicable
在土壤中的流动性 <b>Mobility in soil</b>	不适用 Not Applicable
持久性和分解性 <b>Persistence and Degradability</b>	不适用 Not Applicable
生物聚积 <b>Bioaccumulation potential</b>	不适用 Not Applicable
其他不利影响 <b>Other Adverse Effects</b>	不适用 Not Applicable

第十三部分-废弃处置



## Section 13- Disposal Considerations

<b>产品废弃处理建议</b> <b>Product disposal recommendation</b>	遵守当地、州和联邦法律和法规。 Observe local, state and federal laws and regulations.
<b>包装处理建议</b> <b>Packaging disposal recommendation</b>	废弃处理必须根据当地法规 Disposal must be made according to official regulations

### 第十四部分-运输信息

## Section 14 - Transport Information

<b>运输标签</b> <b>Label for conveyance</b>	锂电池标签 Lithium Battery Label	
<b>UN 编号</b> <b>UN Number</b>	UN 3480 或 UN 3481 UN 3480 or UN 3481	
<b>运输风险类别</b> <b>Transport hazard class(es)</b>	9	
<b>包装等级</b> <b>Packing group</b>	965 or 966	II
	967	--
<b>海洋污染物</b> <b>Marine pollutant</b>	无污染 No	
<b>联合国运输专用名称</b> <b>UN Proper shipping name</b>	锂离子电池(包括锂离子聚合物电池) Lithium ion Batteries (Including lithium ion polymer batteries) 锂离子电池和设备包装在一起(包括锂离子聚合物电池) Lithium ion Batteries packed with equipment (Including lithium ion polymer batteries) 设备里内含锂离子电池(包括锂离子聚合物电池) Lithium ion Batteries contained in equipments (Including lithium ion polymer batteries)	
<b>ICAO/IATA</b>	可根据国际民用航空组织(ICAO), TI或国际航空协会(IATA) DGR 65 版本包装说明 965 第 IA 节规定或 966~967 第 I 节规定进行空运 Can be shipped by air in accordance with international Civil Aviation Organization (ICAO), TI or International Air Transport Association (IATA) DGR 65 <sup>th</sup> Packing Instructions Section IA of 965 or Section I of 966~967 appropriately.	



<b>IMDG CODE</b>	《国际海运危险货物规则》(IMDG CODE)相关规定 IMDG CODE (Amdt 41-22) International Maritime Dangerous Goods Code IMDG CODE (Amdt 41-22)
<b>ADR</b>	《国际危险货物道路运输欧洲协定》(ADR)相关规定 European Agreement concerning the International Carriage of Dangerous Goods by Road
<b>RID</b>	《国际危险货物铁路运输欧洲协定》(RID)相关规定 Regulations concerning the International Carriage of Dangerous Goods by Rail

危险品规例规定，运输前，每一个电池设计须通过联合国试验和标准手册38.3节所载的测试。

The dangerous goods regulations require that each battery design be subject to tests contained in Section 38.3 of the UN Manual of Tests and Criteria prior to being offered for transport.

第十五部分 法规信息

**Section 15- Regulatory information**

法律信息

**Law information**

- 《危险物品规则》
- 《Dangerous Goods Regulations》
- 《对危险货物运输的有关规定的建议》
- 《Recommendation on the Transport of Dangerous Goods Model Regulations》
- 《国际海运危险货物规则》
- 《International Maritime Dangerous Goods》
- 《危险品安全运输技术指令》
- 《Technical Instructions for the Safe Transport of Dangerous Goods》
- 《危险货物分类和品名编号》
- 《Classification and code of dangerous Goods》
- 《消费产品安全法》
- 《Consumer Product Safety Act》(CPSA)
- 《联邦环境污染控制法》
- 《Federal Environmental Pollution Control Act》(FEPCA)
- 《资源保护及恢复法案》
- 《Resource Conservation and Recovery Act》(RCRA)
- 《国际危险货物道路运输欧洲协定》
- 《European Agreement concerning the International Carriage of Dangerous》
- 《国际危险货物铁路运输欧洲协定》
- 《Regulations concerning the International Carriage of Dangerous》

根据所有联邦、州和地方法律。

In according with all Federal, State and local laws.



## Section 16- Other Information

上面的信息被认为是准确代表了目前最好的信息提供给我们。然而,飞机没有对商品性能保证或任何其他保证,包括明示或暗示,对这类信息的使用我们不承担责任。用户应作出自己的调查,以确定是否适合其特定用途的信息。虽然在此处所包含的数据的准备已经采取了合理的预防措施,这是仅为你提供提供的信息、考虑和调查。这个化学品安全技术说明书为本产品提供了安全操作指南和使用指南,它并不能对所有可能发生的情况提供建议,因此,您特殊使用该产品应先进进行评估,以确定是否需要额外的预防措施。

The information above is believed to be accurate and represents the best information currently available to us. However, concorde makes no warranty of merchantability or any other warranty, express or implied, with respect to such information, and we assume no liability resulting from its use. Users should make their own investigations to determine the suitability of the information for their particular purposes. Although reasonable precautions have been taken in the preparation of the data contained herein, it is offered solely for your information, consideration and investigation. This material safety data sheet provides guidelines for the safe handling and use of this product; it does not and cannot advise on all possible situations, therefore, your specific use of this product should be evaluated to determine if additional precautions are required.

-- End of Report --

-- 报告结束 --

