



eFOLDi User Manual

Model: Navigator (STPC-A)



Purchased from:

Date of purchase:

Serial number:

Please see image showing the location of the serial number.



Contents

1	Welcome	2
2	Terms, conditions and disclaimers	3
3	Product overview	5
4	Components	6
5	Safety guidance	8
6	Folding instructions	13
7	Driving your power chair	17
8	Battery and Charging	21
9	Checks and maintenance	25
10	Refurbishment	26
11	Post-Market Surveillance	27
12	Technical specification/EMC declaration	28
13	Information disclosure	34
14	Appendix	41

Welcome

Thank you for choosing an eFOLDi product as your mobility solution.

I'm Sumi Wang, the founder of SunTech UK and would like to welcome you to the eFOLDi family of users.

SunTech UK manufactures a range of assistive technologies to help you get the most from life. Our mission is to give our customers freedom, friendship and fun with a range of easy to use, convenient and market leading mobility solutions.

Your eFOLDi has been manufactured to the highest standards and quality checked by our own pre-sales technicians before delivery, to provide you with a product that will give many years of freedom and fun with reliable service.

Please take some time to read the user manual and the supplied documents before using your eFOLDi for the first time, this will help you understand the product and help you obtain maximum enjoyment and safety from your new eFOLDi product(s). You will quickly become familiar with the features of your eFOLDi with a little practice.

SunTech UK prides itself on its high-quality products and customer support so please remember to register your product(s) at: <https://efoldi.com/register-warranty>

This will help us to assist you in the event of any difficulties you may experience in the future. I am sure you will find your eFOLDi to be a reliable friend and companion and I thank you for your custom and your trust in our products.

Yours,



Sumi Wang

Terms, conditions and disclaimers

The terms 'us', 'we', 'our', 'SunTech UK' and 'SunTech UK Ltd' mean SunTech UK Limited, which is a UK registered company, limited by guarantee, registered with Companies House, number 06906908. The term 'website' means the website found online at www.efoldi.com. The terms 'you', 'your', 'user' and 'rider', mean the person using the eFOLDi notwithstanding any person(s) handling the eFOLDi on behalf of the user, if different to the user, including general handling, maintenance, repairs and so on.

Purchase agreement

By accepting delivery of this eFOLDi, you undertake to not change, alter or modify this eFOLDi and/or any parts supplied with it or subsequently for it, and/or render inoperable or unsafe, any guards, shields or other safety features of this product; fail, refuse or neglect to install any retrofit kits from time to time, as may be provided by SunTech UK Ltd to enhance and/or preserve the safe use of this product. You also agree to accept and abide by/with the terms and conditions contained herein and as may be revised from time to time and updated on our website, being immediately applicable. By using the eFOLDi and/or accessories and/or components supplied with/or for the eFOLDi, the user acknowledges having read and understood the use(s) and limitations of the product(s) without exceptions. This shall not act as a waiver of any implied warranties, which the customer retains, as provided by law.

Warranties will be void and SunTech UK Ltd will accept no responsibility whatsoever or howsoever, in instances of misuse and/or abuse of the products, in part or in full, by the user and/or any unauthorised persons, which may include (but not to be limited to); the user(s) failing to comply with all legal requirements and guidelines, wherever and/or however it is used or intended to be used, lack of/or inappropriate maintenance, maintenance (apart from the routine maintenance as described in this manual by the user) by anyone not approved to do so, unapproved repairs, unauthorised disassembly of the vehicle and/or components including (but not limited to) battery pack(s) and controllers, unapproved modifications or alterations, failure to ensure correct folding and unfolding procedures are followed precisely and in full, damage or injury howsoever caused, failure to apply all reasonable and appropriate safety precautions at all time, improper use of the vehicle and/or parts and/or accessories being used by more than one person at any times, use in any competitive sport, racing, stunts, jumping or other similar activity.

Our liability and the liability of our suppliers, to you/or any third parties in any circumstances is limited to the user's cost of qualifying products purchased. Qualifying products as acceptable for return, as outlined in return policy, as stated on the website online at: www.efoldi.com/return-policy.

Information in this user manual is subject to change without prior notice. For the latest updates and information, please go to our website online at: www.efoldi.com.

DISCLAIMER: SunTech UK Ltd is not and cannot be held responsible for any damage or injury incurred due to improper or unsafe use of the eFOLDi powerchair STPC-A. SunTech UK Ltd specifically disclaims responsibility for any bodily injury or property damage that may occur during any use that does not comply with applicable federal, state, or local laws or ordinances.

Intended use:

The Power Wheelchair is an active medical device intended to be used by a disabled person and /or one who has mobility impairments to replace their restriction on walking.

Product compliance:

Safety:	EN12184
EMC:	ISO7176-21
Risk management:	ISO14971
The European Medical Devices:	EU/2017/745
Product class:	A

Shipping and delivery:

By checking against your sales order or invoice, make sure your delivery is complete, as some components may be individually packaged. If you do not receive a complete delivery, please contact us immediately. Where damage has occurred during transport, either to the packaging or the contents, please contact the company responsible.

Product overview

Thank you for purchasing our eFOLDi power chair. This ultra-light electric wheelchair has been carefully researched and developed to be light, energy efficient and easy to operate. Please read this manual carefully before use, so that you are familiar with all the various functions, and understand the required maintenance. This will ensure that the power chair remains in good condition and is safe to use.



(a) Power chair mode



(b) Storage mode

Model: Navigator (STPC-A)

Intended for use:

The eFOLDi powerchair is designed for indoor and limited outdoor use on smooth, level surfaces.

- Homes, apartments, and assisted living facilities;
- Shopping malls, offices, and hospitals;

Components

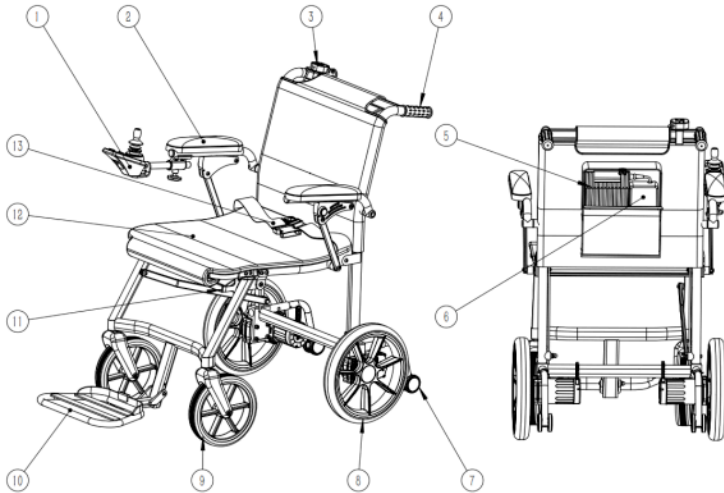

1	Joystick control	2	Armrest
3	Attendant control	4	Push handle
5	Battery	6	Main controller
7	Anti-tip wheels	8	Back solid wheels 12"
9	Front solid wheels 8"	10	Footrest
11	Folding mechanism bar	12	Seat cover
13	Seat belt		

Table 1: Navigator (STPC-A) Components

Control components



1	Joystick control	2	Speed indicator
3	Speed adjustment (slower)	4	Power switch
5	Battery power display	6	Speed adjustment (faster)
7	Horn	8	Reversing sound on/off
9	Attendant control *		

Table 2: Navigator (STPC-A) controls

* Attendant control only works when the main power switch (4) is turned on. Push any buttons on the attendant control to sync it with the Joystick before moving off.

Speed**	Joystick	Attendant control
1	2 km/h	2 km/h
2	3 km/h	3 km/h
3	4 km/h	4 km/h
4	5 km/h	NA
5	6 km/h	NA

Table 3: Power chair speed settings

** Speed may vary due to manufacturing tolerances.

Safety guidance



Attention

- It is the user's responsibility to read the manual and supplied documents before using the eFOLDi and to follow all of the recommendations contained within, to fully comply with all local laws of their countries and localities and to use the eFOLDi with due diligence and regard to other road users and pedestrians.
- The eFOLDi is simple to use, but its folding mechanism can cause significant injury if used inappropriately and handled without due care and diligence. To avoid any risk of injury ensure hands, fingers, jewellery, clothing and other objects are not allowed to interfere with the folding mechanism or moving parts of the eFOLDi and study the manual carefully before you start operating your eFOLDi.
- It is advised that the user familiarise themselves with the folding and unfolding procedure before venturing outside. The user should also ensure that they familiarise themselves with the controls and handling of the power chair in a safe area away from obstacles and other pedestrians or road users.
- Fully charge the battery(ies) before first use and follow the guidelines in this manual for prolonging the life of your battery.

Caution:



Do not get on or off the power chair when the power chair is in freewheel mode

The stopping distance on slopes can be significantly greater than on level ground; The power chair surface temperatures can in-

crease when exposed to external sources of heat (e.g. sunlight)

Cannot be driven on the road.

Be sure to slow down before turning. Do not make sharp turns at high speed. Do not park the power chair on a ramp. Never make turns on a slope.

Please try to avoid riding over rough, cobbled, muddy or loose gravel surfaces. Your power chair is designed for smooth and firm footpaths and pedestrian areas only.

Any vehicle can be dangerous to its rider/driver and other road users and pedestrians. Always ride/drive responsibly, respectfully and with due care to others.

Your power chair is NOT a toy and is not recommended for people under the age of 14. Do not allow children to play with or on the power chair. The internal folding mechanism can cause injury to small hands.

Do not operate your power chair until you have read and fully understood this manual.

Do not operate your power chair until assembly and inspection is complete. A person who has an intellectual or developmental disabilities, slow reactions and difficulty in handling powered devices should not use the power chair on their own.

Do not drive your power chair in violation of national and local traffic regulations.

Do NOT rush when folding or unfolding the power chair.

Do not use the power chair on sandy or soft ground. Avoid driving on slopes greater than 6 degrees or over obstacles greater than 4 cm in height.

Do NOT disassemble or change parts of the power chair or replace parts not manufactured by the manufacturer without the manufacturer's permission.

Never operate the power chair without the anti-tip wheels securely in place.

Do NOT for any reason put your hands into the mainframe of the power chair. This is because your hands and fingers can get trapped in the levers and pivots and serious injuries can be caused.



When unfolding/folding your power chair ensure:

- The eFOLDi is positioned on a level floor or ground.
- Main switch is switched off.
- All latch pins are properly secured in place, as stated on the instructions and shown on the illustrations.



Safety check before use:

It is highly recommended that you perform a safety check before each use to make sure your eFOLDi operates smoothly and safely.

- Check for correct tyre inflation, if pneumatic tyres fitted. Maintain but do not exceed the manufacturer recommended tyre pressure rating indicated on the pneumatic tyres;
- Check all electrical connections. Make sure they are secure and not corroded;
- Check and test the brake system;
- Check frequently for any loose fasteners, fixings and other components.
- Check Anti-tip wheels are securely attached.



Storage conditions:

Your Powered Wheelchair should be stored in a dry place, free from temperature extremes. When storing, disconnect the battery from the Powered Wheelchair. See “Batteries and Charging.”

WARNING! If you fail to store the unit properly, the frame can corrode and the electronics can be damaged.

Batteries that are regularly and deeply discharged, infrequently charged, stored in extreme temperatures, or stored without a full charge may be permanently damaged, causing unreliable per-

formance and limited service life. It is recommended that you charge the battery periodically, every 3 months, throughout periods of prolonged storage to ensure proper performance.

- Storage temperature: -25°C -to 50°C
Storage relative humidity: 60 % ± 20 %
- Some of the parts of the power chair are susceptible to change in temperature. The controller can only operate in temperature that ranges between - 25°C to 50°C.



EMC warning statement

The interference from radio wave sources such as radio stations, TV stations, two way radios or cellular phones can cause the mobility product to release its brakes, move by itself, or move in unintended directions. It can also permanently damage the mobility power chair control system.

The intensity of the interfering EM energy can be measured in volts per meter (V/m). Each mobility product can resist EMI up to a certain intensity. This is called the "EMI immunity level". The higher the EMI immunity level, the greater the protection from EMI. Currently the power chair has an immunity level of at least 20V/m, which provides useful protection from the common sources of EMI.

The sources of radiated EMI can be broadly classified into three types: 1) Hand-held portable transceivers. (normally with antenna mounted on the device) 2) Medium-range mobile transceivers, such as those used in police cars, fire trucks, ambulances and taxis. (normally with antenna mounted on the vehicle) 3) Long-range transmitters and transceivers, such as commercial broadcast transmitters (radio and TV broadcast antenna towers) and amateur (HAM) radios.

Other types of hand-held devices, such as cordless phones, laptop computers, AM/FM radios, TV sets and small appliances such as electric shavers and hair dryers are usually not likely to cause EMI problems.



MR Safety statement



"The eFOLDi Navigator is MR Unsafe. The device presents a projectile hazard."

Folding instructions

To a Power chair mode



Please study the instructions and image illumination to familiarise yourself with the folding procedures and please only operate one moving part at the same time.

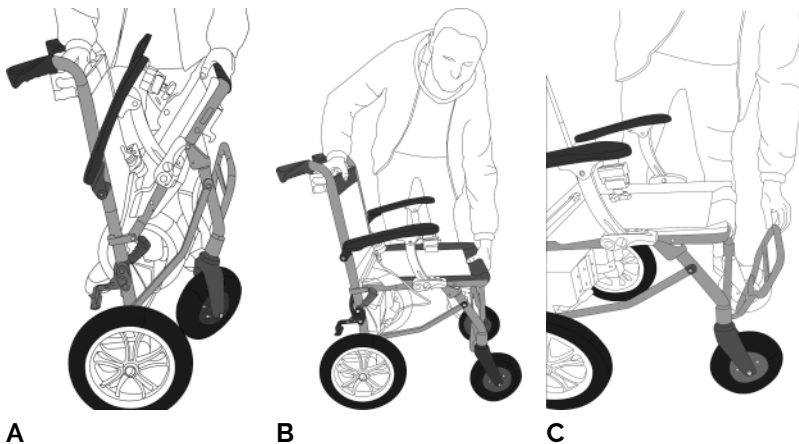

A Once removed from the packaging place the wheelchair on a stable surface. Place one hand on the top of the backrest and the other hand on the folding mechanism bar underneath the seat, in the front part of the folded power chair.

B Finally push your two hands apart until the seat is open at 90° degrees and you hear a distinct "click" sound.

C Unfold the footrest, from a vertical position to a 90° degrees horizontal position.

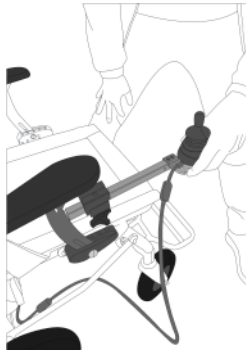

D

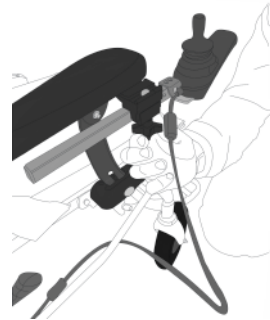

E

D Slot the joystick arm inside the frame and push it into a comfortable horizontal position, where it is easy for your hand to reach the joystick.

E Once you are happy with the horizontal position of the joystick arm, lock it by tightening the clamp. Finally attach Anti-tip wheels securely on the back of the power chair before driving off. Make sure they 'Click' properly into position (see image below).



To a Storage mode



Please study the instructions and image illumination to familiarise yourself with the folding procedures and please only operate one moving part at the same time.

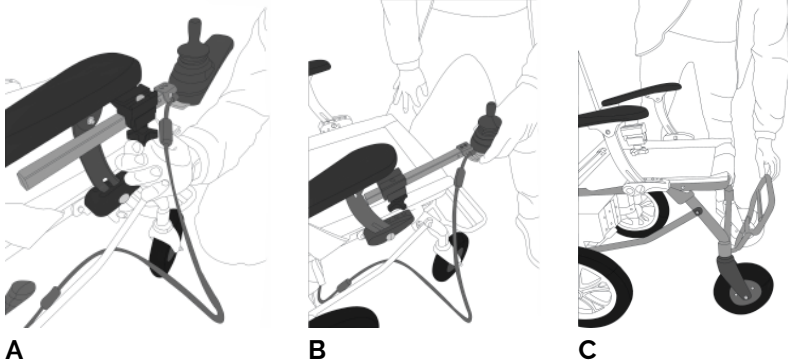

A Loosen the tightening clamp, to release the joystick arm.

B Take out the joystick arm and place it on the power chair seat.

C Fold the footrest, at 90° degrees position vertically.



E

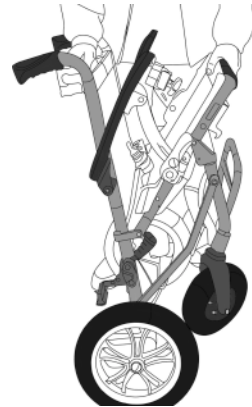

F

E Then place one hand at the top on the backrest bar and the other on the folding mechanism bar underneath the seat.

F By pressing the folding mechanism bar and bringing your hand together to close and fold the Power chair. Your power chair is ready to be stored or transported.



Driving your power chair



Safety check before use - see Safety Guidance

The eFOLDi power chair is suitable to use indoors or drive on the pavement only and is designed to drive on smooth even surfaces. When driving your eFOLDi, choose a route with good road conditions. Unevenly paved roads or paths, potholes and other hazards will reduce the life of the power chair and impact on your safety.

Any deviation from level/horizontal surfaces should not exceed a gradient of 1:10 (6 degrees). For any climbing there are many factors that need to be considered. Such as: the tyre pressure and condition, the surface condition (if wet, icy or slippery, and this includes leaf cover and/or other debris, we advise against driving the slope), battery charge and the weight of the user, all of these will affect performance.

Caution:

The stopping distance on slopes can be significantly greater than on level ground; The power chair surface temperatures can increase when exposed to external sources of heat (e.g. sunlight)

We recommend for safety purposes on any significant incline up to 6 degrees, a minimum speed of 3 (lights) out of 5 is used, to avoid a lack of Power Chair momentum when climbing the slope to avoid stopping or reducing the chance of tipping backwards. This is all subject to variables such as the condition of slope, gradient of slope, length of slope and weight of user.



Perform the safety check before each use - see Safety Guidance section.

Operate the power chair

- To Start - Switch on the main power switch (4) and press the power button on the joystick to switch on the power chair.



Joystick controller

- To Stop - Switch off the power switch (4) on the joystick
- Adjust the speed - Use speed adjustment button to reduce (3) or increase (6) the speed.
- Drive forward - Push the Joystick controller stick (1) forward.
- Turn left/right - Push the Joystick controller stick (1) left/right.
- Drive backward - Push the Joystick controller stick (1) backward.
- Use attendant control - Power on the attendant control (9) and push the lever forward to go forward, push the lever back to go backward.

When Attendant Control (9) is in use, the chair no longer responds to the Joystick controller (1).

- Joystick controller (1) controls the direction and speed at the same time, slowly push the joystick towards the driving direction, then the eFOLDi Power chair will start to move, push the joystick further and you will notice greater acceleration.
- Speed adjustment - slower (3) It is positioned just above the control handle on the left hand side, and it decreases the speed (from 5 to 1) to make the eFOLDi power chair easier to control.
- Power display (5) Shows the battery charge remaining.
- Power button (4) Switches the power on and off by pressing the button (Make sure the main power switch is on).

- Horn (7) Positioned right in the middle of the control panel, use this to warn other pedestrians of your presence.
- Speed adjustment - faster (6) It is positioned just above the control handle on the right hand side, and by pressing the button it increases the speed level (from 1 to 5) of the power chair to go faster. Always be aware of your speed.
- Speed display (2) Indicates what speed is currently selected, between 1 to 5.
- Attendant control (9) Allows an assistant to power the chair for easy handling. Also it has its own power on/off button.
- Reversing sound on/off button (8) Allows you to turn the reversing beep on or off.

Freewheel/motor bypass mode

Set the red brake handles from Drive position (locked sign) to Freewheel position (unlocked sign) on both motors to engage the freewheel mode.

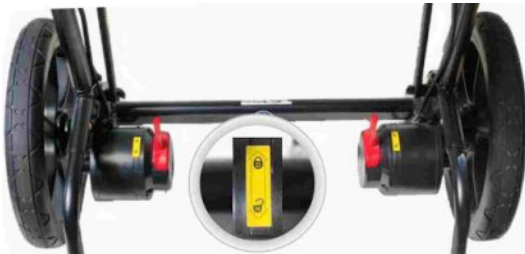

Set the red brake handles from Freewheel mode (unlocked sign) to Drive position (locked sign) to re-engage both motors.

Transporting a power chair:

To safely transport the power chair, first ensure it is powered off. Fold the chair according to the manufacturer's instructions, securing any loose parts. Lift using the designated handles or frame sections, avoiding delicate components. Place it in the vehicle with the battery properly secured. If necessary, use straps to prevent movement during transport.

Warning:

The product is not intended to be used as a seat in a motor vehicle including public transport. You will need to take a seat on your mode of transport.



Battery and Charging

The power chair battery has been designed and built specifically for the eFOLDi power chair. This battery must not be used for any purpose other than as stated in this manual. Any misuse or dismantling of this battery may damage it physically and/or electrically, internally and/or externally and will not be covered by warranty. The battery contains no user serviceable or replaceable components. The power chair battery is actually a battery pack, comprising a number of lithium ion cells, but merely termed 'battery' for ease throughout this manual. This battery is different in characteristics and charging requirements to the old and still quite common lead/acid or lead/gel type. Never use a lead type charger to charge it.

It is highly recommended to ensure the charger is placed only on heat resistant surfaces and nothing which could contribute to a fire (e.g. carpet, floorboards, wood, laminate or plastic worktops etc)- the charger will heat up during a normal charging cycle, as will the battery.

To ensure best long-term use of the battery, please observe the following safety rules at all times.

- Charge the battery ONLY with the approved charger, only batteries of the specified type and capacity are to be charged.
- Never use a charger for lead type batteries on the eFOLDi battery.
- Never place the battery near, on or against any heat source.
- Charging is carried out with the wheelchair in a space at least twice its volume, with sufficient ventilation so that there is no hazard due to a build-up of flammable gas.
- Ensure no metal parts can touch (or 'short') battery or charger terminals, connectors, pins or any other electrical conductor(s) or conducting parts.
- Avoid excessive physical impact and vibration of the battery.
- Do not attempt to dismantle, dissect or deform the battery or case.
- Do not immerse the battery in any liquid (including water).
- Do not mix different types of batteries.
- Keep the battery out of reach of children.
- Do not use modified or damaged chargers.
- Do not leave the battery on charge overnight.
- Store the battery in a cool, dry, well ventilated area.

- Dispose of the battery only in accordance with local laws and regulations.
- Batteries should not be stored for long periods without charging. It is recommended the battery to be charged monthly to prolong its life.
- Never store the battery when it is significantly discharged.
- For the benefit of international travellers, your approved eFOLDi charger can be used with any mains voltage supply from 100 to 240 Volts, with a suitable travel adaptor.
- Explosive gasses can be generated while charging, so the wheelchair and battery charger are to be kept away from sources of ignition, such as flames and sparks.
- It is OK that occasional use of the power chair prior to full charging indication is acceptable, if the need is urgent.
- Disconnect the main power plug first before removing the charger from the charging port after the charging is completed.

Battery power display

Switch on the power, the power display light in the front row will be on, full power will show 5 lights (1 red, 2 yellow, 2 green). When the red light is flashing, this indicates that the battery requires charging.

Charger and Charging

Use only the charger originally supplied with your new power chair or replacement charger supplied by SunTech UK Ltd for the use with your product. The use of a non-approved charger will invalidate any warranty and may cause serious damage to the battery and/or your eFOLDi product. The charger should not be used with/or for other devices as damage caused to the charger and/or any other device by doing so will not be covered by our warranty.

Do not leave the battery on charge for more than 24 hours, as this will reduce the life and performance of the battery.

You can charge the battery in 2 ways:

1. Charge via Joystick - plug the charger lead into the base of the joystick controller and connect the AC plug to a power outlet.
2. Charge directly to battery - battery can be charged after removing it from the bag by using the same charger.

LED light on the charger turns Red indicating the battery is charging. It will turn green when it is fully charged.

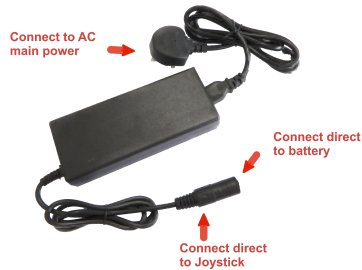

Standard charger

If the joystick display is on when the battery charger is plugged into the charging port on the back of the joystick. The battery indicator will flash irrespective of whether the charger is connected to a power outlet or not. Always look at the LED light on the charger to check if the battery is being charged (Red light on charger - means the battery is being charged).



1. Charge via Joystick



2. Charge directly to battery

Do NOT use any other cable than eFOLDi 24VDC power chair charger to charge.

Stop Using a Damaged Battery Charger Immediately if your charger has the following signs:

1. Frayed/Exposed wires
2. Burn marks, melted plastic, or unusual odors
3. Intermittent charging or overheating

4. Cracked casing or loose connectors

Continuing to use a faulty or damaged charger can lead to severe risks, including:

1. Fire or Explosion:
2. Electric Shock:
3. Battery damage.
4. Device damage.

Checks and maintenance



- Perform the following inspections prior to using your power chair:
Check the fastening condition of all nuts, bolt and screw to make sure all the parts are properly secured and are not missing or loose. Check all electrical connections. Make sure they are tight and not corroded. The braking distance should be less than 1.5 metres after you release the joystick to stop.
- Cleaning and maintenance:
Periodic cleaning of your eFOLDi will help to maintain its appearance and will both extend the life of the vehicle and improve resale value. Metal and plastic parts can be wiped with a damp cloth using a mild detergent.
- Have your eFOLDi regularly serviced each year.

Expected Service Life:

The product has an expected service life of 5 to 7 years under normal usage conditions. The actual lifespan may vary depending on factors such as frequency of use, maintenance, and environmental conditions.

Caution:

Oil and other lubricants must NOT be used on the tyres.

Refurbishment



- **Refurbishment for re-use**

The product is suitable for refurbishment and re-use.

Actions to be carried out:

Cleaning and disinfection. Please see section "Checks and maintenance".

Inspection according to service plan.

Please consult with an authorised dealer for inspection, service and maintenance before re-use, or contact eFOLDi customer service if purchased directly from us.

Post-Market Surveillance

As part of our commitment to product safety and compliance, we conduct post-market surveillance (PMS) to monitor the performance and reliability of this power chair after sale.

Reporting Issues and Safety Concerns:

If you experience any issues related to performance, durability, battery life, or safety, please contact us immediately:

Customer Support Hotline:

+44 (0) 20 3143 5168

Email:

services@efoldi.com

Website:

www.efoldi.com

Address:

**25 Ormside Way,
Redhill, Surrey, RH1 2LW**

Technical specification/EMC declaration

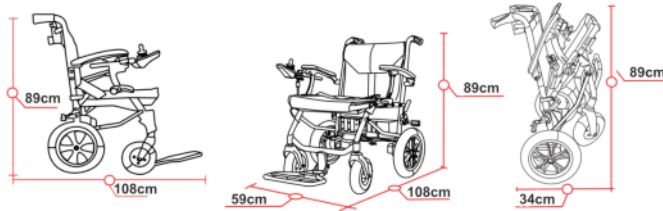

Frame material	Magnesium alloy
Dimension	
Packaging size (L/W/H):	36x61x92cm (15x24x36")
Folded size (L/W/H):	34x59x89cm (13x23x35")
Unfolded size (L/W/H):	108x59x89cm (43x23x35")
Front wheel size:	20cm (8")
Rear wheel size:	30cm (12")
Seat width:	45cm (18")
Maximum ground clearance:	4cm (1.5")
Weight	
Weight with battery:	14kg/31lbs**
Weight without battery:	12.4kg/27lbs **
Performance	
Speed:	4mph (6kmh)
Maximum range capacity:	8miles (13km)
Maximum carry capacity:	120kg (265lbs/19stone)
Maximum Incline:	1:10 Gradient (6 degrees)
Turning radius left/right:	120cm (40 inches)
Maximum kerb height:	3cm (1.2")
Components capability	
Motor:	2 x 180W, 24VDC
Battery:	10Ah 24VDC Lithium Ion
Charger:	Input 100-240VAC, 50/60Hz, output 29.4V 2A
Brake:	Electro magnetic
Power switch:	Power button on joystick
Number of Wheels:	4
Tyre type:	Solid

**excludes optional accessories

Table 4: Specification: Navigator (STPC-A)

Legal Disclaimer Notice:

All product, product specifications and data are subject to change without notice to improve reliability, function or design or otherwise. Specifications may vary due to manufacturing tolerances.

EMC Guidance and Manufacturer's Declaration

Below cable information is provided for EMC reference.

Cable	Max. cable length, Shielded/unshielded		Number	Cable classification
AC Power Line	1.5m	Unshielded	1 Set	AC Power
DC Power Line	1.5m	Unshielded	1 Set	DC Power

Important information regarding Electro Magnetic Compatibility (EMC)

This electrical medical equipment needs special precautions regarding EMC and put into service according to the EMC information provided in the user manual; The equipment conforms to this IEC 60601-1-2:2014 standard for both immunity and emissions. Nevertheless, special precautions need to be observed:

The equipment with following ESSENTIAL PERFORMANCE is intended to be used in home healthcare environment.

ESSENTIAL PERFORMANCE:

The average wheel speed of the scooter is not able to change, exceeding $\pm 20\%$

WARNING: Use of this equipment adjacent to or stacked with other equipment should be avoided because it could result in improper operation. If such use is necessary, this equipment and the other equipment should be observed to verify that they are operating normally.

The use of accessories, transducers and cables other than those specified or provided by the manufacturer of this equipment could result in increased electromagnetic emissions or decreased electromagnetic immunity of this equipment and result in improper operation.

WARNING: Portable RF communications equipment (including peripherals such as antenna cables and external antennas) should be used no closer than 30 cm (12 inches) to any part of this product, including cables specified by the manufacturer. Otherwise, degradation of the performance of this equipment could result.

WARNING: If the use location is near (e.g. less than 1.5 km from) AM, FM or TV broadcast antennas, before using this equipment, it should be observed to verify that it is operating normally to assure that the equipment remains safe regarding electromagnetic disturbances throughout the expected service life.

Test	Power input voltage	Power frequency	Remark
Conducted DISTURBANCES (Conducted EMISSIONS) CISPR 11	AC 100V AC 240V	60Hz 50Hz	Charger
Electromagnetic radiation disturbance (Radiated EMISSIONS) CISPR 11	AC 100V AC 240V DC 24V	60Hz 50Hz	Charger Battery
Harmonic current EMISSIONS IEC 61000-3-2	AC 230V	50Hz	Charger
Voltage changes, voltage fluctuations and flicker EMISSIONS IEC 61000-3-3	AC 230V	50Hz	Charger
ELECTROSTATIC DISCHARGE IMMUNITY IEC 61000-4-2	AC 230V DC 24V	50Hz	Charger Battery
Radiated RF electromagnetic field IMMUNITY IEC 61000-4-3	AC 230V DC 24V	50Hz	Charger Battery
IMMUNITY to proximity fields from RF wireless communications equipment IEC 61000-4-3 (interim method)	AC 230V DC 24V	50Hz	Charger Battery
Electrical fast transient/burst IMMUNITY – a.c. mains IEC 61000-4-4	AC 230V	50Hz	Charger
Electrical fast transient/burst IMMUNITY– I/O SIP/SOP PORTS IEC 61000-4-4	N/A	N/A	N/A
Surge IMMUNITY IEC 61000-4-5	AC 230V	50Hz	Charger

IMMUNITY to conducted DISTURBANCES induced by RF fields conducted RF DISTURBANCE IMMUNITY) - a.c. mains IEC 61000-4-6	AC 230V	50Hz	Charger
IMMUNITY to conducted DISTURBANCES induced by RF fields (conducted Disturbance IMMUNITY) - SIP/SOP PORTS IEC 61000-4-6	AC 230V	50Hz	Charger
Power frequency magnetic field IMMUNITY IEC 61000-4-8	AC 230V DC 24V	50/60Hz	Charger Battery
Voltage dips IMMUNITY IEC 61000-4-11	AC 100V AC 240V	50Hz 50Hz	Charger
Voltage short interruptions and voltage variations IMMUNITY IEC 61000-4-11	AC 100V AC 240V	50Hz 50Hz	Charger

Table 3: Power input voltages and frequencies during the tests

EMI Compliance Table (Table 4)

Phenomenon	Compliance	Electromagnetic environment
RF emissions	CISPR 11 Group 1, Class B	Home healthcare environment
Harmonic distortion	IEC 61000-3-2 Class A	Home healthcare environment
Voltage fluctuations and flicker	IEC 61000-3-3 Compliance	Home healthcare environment

Table 4: Emission

EMS Compliance Table (Table 5-8):

Phenomenon	Basic EMC standard	Immunity test levels
		Home healthcare environment
Electrostatic Discharge	IEC 61000-4-2	±2kV, ±4kV, ±6kV, ±8 kV contact ±2kV, ±4kV, ±8kV, ±15kV air
Radiated RF EM field	IEC 61000-4-3	20V/m 26MHz-2.7GHz 80% AM at 1kHz
Proximity fields from RF wireless communications equipment	IEC 61000-4-3	Refer to table 3
Rated power frequency magnetic fields	IEC 61000-4-8	30A/m 50Hz or 60Hz

Table 5: Enclosure port

Test frequency (MHz)	Band (MHz)	Immunity test levels
		Home healthcare environment
385	380-390	Pulse modulation 18Hz, 27V/m
450	430-470	Pulse modulation 18Hz, 28V/m
710	704-787	Pulse modulation 217Hz, 9V/m
745		
780		
810		
870	800-960	Pulse modulation 18Hz, 28V/m
930		
1720		
1845	1700-1990	Pulse modulation 217Hz, 28V/m
1970		
2450		
5240	5100-5800	Pulse modulation 217Hz, 9V/m
5500		
5785		

Table 6: Proximity fields from RF wireless communications equipment

Phenomenon	Basic EMC standard	Immunity test levels
		Home healthcare environment
Electrical fast transients/burst	IEC 61000-4-4	±2 kV 100kHz repetition frequency
Surges Line-to-line	IEC 61000-4-5	±0.5 kV, ±1 kV
Conducted disturbances induced by RF fields	IEC 61000-4-6	3V, 0.15MHz-80MHz 6V in ISM bands and amateur radio bands between 0.15MHz and 80MHz 80%AM at 1kHz
Voltage dips	IEC 61000-4-11	0% UT; 0.5 cycle At 0°, 45°, 90°, 135°, 180°, 225°, 270° and 315°
		0% UT; 1 cycle, and 70% UT; 25/30 cycles Single phase: at 0°
Voltage interruptions	IEC 61000-4-11	0% ut; 250/300 cycles

Table 7: Input a.c. power Port

Phenomenon	Basic EMC standard	Immunity test levels
		Home healthcare environment
Conducted disturbances induced by RF fields	IEC 61000-4-6	3V, 0.15MHz-80MHz 6V in ISM bands and amateur radio bands between 0.15MHz and 80MHz 80% AM at 1kHz

Table 8: Signal input/output parts port

Information disclosure

ISO 7176-3:2012			
Clause	Requirement + Test	Result – Remark	Verdict

Table 2	Results of brake tests						P
Parking brake tests							
	Test condition	Angle		Force applied ^{a)}			
	Maximum slope uphill	18.5°		N/A			
	Maximum slope downhill	12.2°		N/A			
	Brake bar operating force	51.2 N					
Running brake tests							
	Test plane inclination	Direction of travel	Maximum speed	Normal operation	Reverse command	Emergency operation	Comments / any abnormal behaviour ^{b)}
			(m/s)	(m)	(m)	(m)	
	Horizontal	Forwards	1.56	0.88	0.84	0.86	
	Horizontal	Reverse	0.78	0.37	0.36	0.34	
	3°	Forwards downhill	1.72	1.30	1.29	1.33	
	3°	Reverse downhill	0.80	0.76	0.75	0.78	
	6°	Forwards downhill	1.84	1.61	1.60	1.63	
	6°	Reverse downhill	0.89	1.04	1.05	1.08	
	10°	Forwards downhill	N/A	N/A	N/A	N/A	
	10°	Reverse downhill	N/A	N/A	N/A	N/A	
	Maximum slope specified by the manufacturer 6°	Forwards downhill	1.84	1.61	1.60	1.63	
	Maximum slope specified by the manufacturer 6°	Reverse downhill	0.89	1.04	1.05	1.08	
	Brake operating force	/					
Note:							
a) Increase the angle of the plane until the chair starts to move down the slope. If the wheelchair starts to tip (see 3.1) before sliding (see 3.2) or rolling down the slope, apply the minimum force necessary to prevent the wheelchair from tipping. Apply the force to the uphill wheels in a direction perpendicular to the test plane. Ensure that the force is applied in a manner which has a minimal effect on sliding or rolling.							
b) Record any abnormal behaviour of the wheelchair during braking, such as tipping (see 3.1), sliding (see 3.2), brake failure, or veering to one side.							
c) The wheelchair shall stop in a safe way according to Annex C if the tests cannot be carried out as above.							

ISO 7176-2:2017			
Clause	Requirement + Test	Result – Remark	Verdict

	A Applying reverse	3	3	3	/	anti-tip device.
Forward Dynamic Stability (maximum occupant mass: 120Kg)						
9.3 Braking when travelling forward	R Release	3	3	3	/	
	P Power off	3	3	3	/	
	A Applying reverse	3	3	3	/	
9.4 Travelling forward down a slope onto a horizontal surface		3	3	/		
Dynamic stability in lateral directions (maximum occupant mass: 120Kg)						
10.3 Turning from a stationary start		3	3	3	/	
10.4 Turning in a circle at maximum speed (minimum diameter in metres)		1.20 m				
10.5 Turning suddenly at maximum speed	Turning right	3				
	Turning left	3				
Supplementary information (Description of changes of the wheelchair in the final configuration, and if there any changes, please post relevant photos in the table appendix): Note1: Human test driver used. Note2: The maximum slope specified by manufacture is 6°.						

Table B	Dynamic stability test ^{Note1}					P
Test	Kerb-climbing devices	Stability score			comments	
		Step height(mm)				
		15	25	50 ^{Note2}		
Rearward dynamic stability (maximum occupant mass: 120Kg)						
8.6 Travelling forward up a step transition from a standing start	With kerb-climbing devices	/	/	/	No kerb-climbing device.	
	Without kerb-climbing devices	3	3	3		
8.7 Travelling forward up a step transition at maximum speed	With kerb-climbing devices	/	/	/	No kerb-climbing device.	
	Without kerb-climbing devices	3	3	3		
8.8 Travelling backward down a step transition from a standing start		3	3	3		
Rearward dynamic stability (maximum occupant mass: 100Kg)						
	With kerb-climbing devices	/	/	/	No kerb-climbing device.	

ISO 7176-2:2017					
Clause	Requirement + Test	Result – Remark			Verdict
8.6 Travelling forward up a step transition from a standing start	Without kerb-climbing devices	3	3	3	
8.7 Travelling forward up a step transition at maximum speed	With kerb-climbing devices	/	/	/	No kerb-climbing device.
	Without kerb-climbing devices	3	3	3	
8.8 Travelling backward down a step transition from a standing start		3	3	3	
Forward Dynamic Stability (maximum occupant mass: 120Kg)					
9.5 Travelling forward up a step transition at maximum speed	With kerb-climbing devices	/	/	/	No kerb-climbing device.
	Without kerb-climbing devices	3	3	3	
9.6 Travelling forward down a step transition from a standing start		3	3	3	
Dynamic stability in lateral directions (maximum occupant mass: 120Kg)					
10.6 Travelling forward at an oblique angle to a downward step		3	3	3	
Supplementary information:					
Note1: The observed dynamic response of the wheelchair to the test manoeuvres shall be quantified as specified in Table A.1.					
Note2: The height 50 mm is claimed by the manufacturer.					

ISO 7176-5:2008

Clause	Requirement + Test	Result – Remark	Verdict
--------	--------------------	-----------------	---------

Table 2 Wheelchairs without handrims		
Clause	Measurement items	Measured values
4.2	Type Class	A
4.3	Occupant mass group	II
--	Effective seat width	400mm
8.2	Full overall length	1080mm
8.3	Overall width	590mm
8.5	Stowage length	340mm
8.6	Stowage width	590mm
8.7	Stowage height	890mm
8.8	Rising	80mm
8.9	Total mass	14kg
8.10	Mass of heaviest part	12kg
8.11	Pivot width	1200mm
8.12	Reversing width	1500mm
8.13	Turning diameter	1200mm
8.14	Ground clearance	90mm
8.15	Required width of angled corridor	1000mm
8.16	Required doorway entry depth	1150mm
8.17	Required corridor width for side opening	930mm

Note:

Since these data and / or information is provided by the applicant, the relevant results or conclusions of this report are only made for these data and / or information, SGS is not responsible for the authenticity, integrity and results of the data and information and / or the validity of the conclusion.

ISO 7176-7:1998			
Clause	Requirement + Test	Result – Remark	Verdict

Measurement	Dimension No.	Fixed or minimum value	Maximum value, if relevant
Seat plane angle	(1)	3°	°
Effective seat depth	(2)	350mm	mm
Seat width	(3)	450mm	mm
Effective seat width	(4)	400mm	mm
Seat surface height at front edge	(5)	500mm	mm
Backrest angle	(6)	12°	°
Backrest height	(7)	900mm	mm
Backrest width	(8)	455mm	mm
Headrest in front of backrest	(9)	N/A	mm
Headrest height above seat	(10)	N/A	mm
Footrest-to-seat distance	(11)	410mm	mm
Footrest clearance	(12)	100mm	mm
Footrest length	(13)	290mm	mm
Footrest-leg-angle	(14)	105°	°
Leg-to-seat-surface angle	(15)	100°	°
Armrest-to-seat distance	(16)	230mm	mm
Front armrest-to-backrest distance	(17)	300mm	mm
Armrest length	(18)	260mm	mm
Armrest width	(19)	55mm	mm
Armrest angle	(20)	3°	°
Distance between armrests	(21)	480mm	mm
Front location of armrest structure	(22)	300mm	mm
Handrim diameter	(23)	N/A	mm
Propelling wheel diameter	(24)	293mm	mm
Horizontal location of axle	(25)	146mm	mm
Vertical displacement of wheel axle	(26)	500mm	mm
Castor wheel diameter	(27)	200mm	mm

Note:

Since these data and / or information is provided by the applicant, the relevant results or conclusions of this report are only made for these data and / or information, SGS is not responsible for the authenticity, integrity and results of the data and information and / or the validity of the conclusion.

--- End of ISO 7176-7 test report, continued with ISO 7176-8 test report---

ISO 7176-15:1996			
Clause	Requirement + Test	Result – Remark	Verdict

Disclosure information (ISO)							
Standard reference		min.	max.	Standard reference		min.	max.
ISO 7176-5	Overall length with legrest	1080mm	mm	ISO 7176-7	Seat plane angle	3°	°
ISO 7176-5	Overall width	590mm	mm	ISO 7176-7	Effective seat depth	350mm	mm
-	Folded length	340mm	mm	ISO 7176-7	Effective seat width	400mm	mm
-	Folded width	590mm	mm	ISO 7176-7	Seat surface height at front edge	500mm	mm
-	Folded height	890mm	mm	ISO 7176-7	Backrest angle	12°	°
ISO 7176-5	Total mass	14kg	kg	ISO 7176-7	Backrest height	900mm	mm
ISO 7176-5	Mass of the heaviest part	12kg	kg	ISO 7176-7	Footrest to seat distance	410mm	mm
ISO 7176-1	Static stability downhill	10 °	°	ISO 7176-7	Leg to seat surface angle	100°	°
ISO 7176-1	Static stability uphill	6 °	°	ISO 7176-7	Armrest to seat distance	230mm	mm
ISO 7176-1	Static stability sideways	6 °	°	ISO 7176-7	Front location of armrest structure	300mm	mm
ISO 7176-4	Energy consumption	20km	km	-	Handrim diameter	N/A	mm
ISO 7176-2	Dynamic stability uphill	6 °	°	ISO 7176-7	Horizontal location of axle	146mm	mm
ISO 7176-10	Obstacle climbing	50mm	mm	ISO 7176-7	Minimum turning radius	600mm	mm
ISO 7176-6	Maximum speed forward	6km/h	mm	Manufacturer	Maximum occupant mass	120kg	kg
ISO 7176-3	Minimum braking distance from max speed	1650mm	mm	-	-	-	-

--- End of ISO 7176-15 Test report, continued with ISO 7176-22 Test report---

ISO 7176-25:2013			
Clause	Requirement + Test	Result – Remark	Verdict

Table 5.3.2.1 Charging current							N/A
Constant voltage load $U_{chg} \times (0,97 \pm 0,01)$:		$U_{chg} = V$	Rated output current			$I = A$	
Required output current of the battery charger $I_{chg,min} = 0,5 \times I_5$		$I_{chg,min} = A$	Maximum operating temperature :			°C	
Input mains voltage (Range)	Measured maximum R.M.S. output current(A)	Limits of output current 110% of rated output current, specification of output connector or specification of output cable which is lower(A) ^{Note}				Remark	
V							
Note: The specification is provided by manufacturer of the component							
Supply Voltage: V							
1 st h	10 min	20 min	30 min	40 min	50 min	60 min	
output current (A)							
2 nd h	10 min	20 min	30 min	40 min	50 min	60 min	
output current (A)							
3 rd h	10 min	20 min	30 min	40 min	50 min	60 min	
output current (A)							
4 th h	10 min	20 min	30 min	40 min	50 min	60 min	
output current (A)							
Maximum R.M.S. output current(A)							
Arithmetic mean output current(A)							

Table 5.3.2.2 Charging Voltage							N/A
Rated d.c. output voltage.....:		$U_{chg} = V$	The maximum battery capacity.....:			$C_6 = Ah$	
Minimum output voltage $U_{chg} \times 0,995$		$U_{chg,min} = V$	Output current of the battery charger			$I_{chg,min} = A$	
Maximum output voltage $U_{chg} \times 1,005$:		$U_{chg,max} = V$	Maximum operating temperature.....:			°C	
Input Mains Voltage	Measured Maximum Output Voltage (V)		Measured Minimum Output Voltage (V)				

-End of ISO 7176-25 Test report, Continued with Attachment 1 Technical documentation-

Appendix



SunTech UK Ltd

25 Ormside Way, Holmethorpe Industrial Estate, Redhill, Surrey, RH1 2LW

TEL: +44 (0) 2031435168



MedPath GmbH



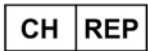







Mies-van-der-Rohe-Strasse 8, 80807 Munich, Germany

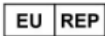

ALBO-Healthcare GmbH

Alte Steinhäuserstrasse 19, CH-6330 Cham

Symbols used on the label

	European CE Marking		Manufacturer
	Authorized representative in the European community		Medical device
	Serial number		Unique Device Identification
	Date of manufacture		Refer to instruction manual
	Swiss authorised representative		UK Conformity Assessed



(eFOLDi accessories)
www.efoldi.com/shop



SunTech UK Ltd
25 Ormside Way, Redhill,
Surrey, RH1 2LW, UK

**UK
CA**



MedPath GmbH
Mies-van-der-Rohe-Strasse 8
80807 Munich, Germany

CE



ALBO-Healthcare GmbH
Alte Steinhauserstrasse 19
CH-6330 Cham

Official website address: www.efoldi.com
Service email: services@efoldi.com
Facebook: www.facebook.com/efoldi.co.uk